

FONTANA LIMA COMMERCIAL CHROME WALL MOUNT MOTION SENSOR FOAM SOAP DISPENSER SPECS

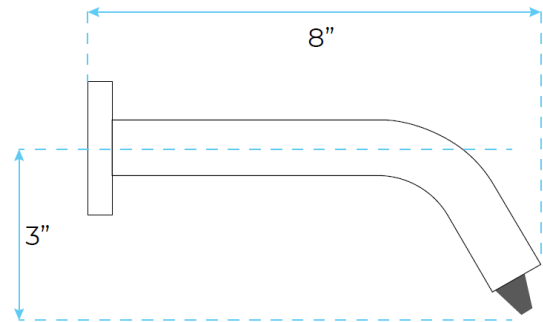

SPECS:

Product Type: Commercial

Main Construction Material: Brass

Mount Type: Deck

Handle Type: Infra-Red

Power Rating: DC: 6V (4x 1.5VAA alkaline battery) AC:220V

Batteries Required: 4 AA Batteries (not supplied)

Number of Tap Holes: 1

Valve/Cartridge Type: Solenoid Valve

Plumbing System Requirements: Suitable for all plumbing systems

Sensing Range: 15 _ 3cm

Activation Time: 0.5 - 1 secs

Viscosity of Liquid Soap: 100-3500cp (mpA .s)

Soap volume: <2m/time (Four gear)

